

# Vector Control of Z-Source Inverter Fed PMSM Using SVPWM

Sreejaya.R

NSS College of Engineering, Palakkad, Kerala, India.

Vasanthi.V

NSS College of Engineering, Palakkad, Kerala, India.

Sangeeth.B.S

NSS College of Engineering, Palakkad, Kerala, India.

**Abstract** – Permanent-magnet synchronous motors (PMSM) are widely used in modern variable speed AC drives, especially in electric vehicle (EV) due to high torque-to-current ratios, high power-to weight ratios, high efficiency and robustness. This paper deals with the simulation and operation of PMSM drive system with Z-Source Inverter. The Z-source inverter overcomes the barriers and limitations of the traditional voltage-source inverter and current-source inverter. It has the main features that the output voltage can be bucked or boosted by controlling the shoot-through duty cycle and has the lower input current harmonics distortion, a high efficiency, as it makes possible to avoid voltage spikes on the switches. By introducing ZSI to the vector controlled scheme of PMSM drive system, the DC-link voltage is controllable so that PMSM can operate at high speed. The feasibility and effectiveness of the system is verified by simulation and experimental results.

**Index Terms** - Z-source Inverter, PMSM Drive, Vector control.

## 1. INTRODUCTION

Many types of electric motors are used in the industry for different purposes: cranes, spinning machines, transportation and so on. Recently, ac drives in vehicle applications are gaining attention due to increasing pollution and fuel price problems. In the electrical system of an electric or hybrid electric vehicle based on an ac motor, the motor is producing torque from the battery through the inverter. Although motors with different structures were used to propel the vehicles, the permanent magnet synchronous motors (PMSM) provides high efficiency, robustness and high reliability.

The power density of PMSM is higher than induction motor of same ratings due to the fact that no stator power used for the magnetic field production. Power-electronic converters are becoming popular for various industrial drives applications [1]. PWM inverter fed PMSM drive are extensively used in variable speed applications. Although a better sinusoidal motor current waveform with fewer ripples with reduced copper losses and switching losses is obtained, due to the fast switching operations, there is a significant increase in  $dv/dt$  which results in over-voltages [2].

## 2. RELATED WORK

The traditional inverter based PMSM drive system consists of a front end three phase diode rectifier, DC link LC filter, and three phase Inverter Bridge. The voltage-source inverter (VSI) performs only the voltage buck conversion, which limits its application in the fields with large input voltage, such as the renewable energy system. To extend the input voltage range, a boost converter is usually inserted in the front end. Hence needs an additional active switch either with separated controller and drive system for the two stages. By introducing a passive network with two inductors and two capacitors into the voltage-source inverter, the Z-source inverter (ZSI) can buck and boost its output voltage in a single stage without additional active switch [2]. The additional shoot-through state which is forbidden in VSI is utilized to boost the voltage in ZSI. Compared to the two-stage structure, the system structure of ZSI is simplified [1]. In the ZSI, the introduced impedance network influences the system weight and volume greatly. The system power density can be improved by minimizing the size of impedance network. The size of the Z-source capacitors will be minimized by the improvement of ZSI topology. ZSI is adopted for various applications, such as fuel cell energy conversion systems and induction motor drives [3]. In series ZSI, the power source is series connected with the inverter bridge and shows the reduced voltage across both capacitors with soft start capability [11].

A bidirectional ZSI (BZSI) topology has been proposed in [5], where the basic ZSI topology was changed into a bidirectional ZSI topology by replacing the input diode, D, with a bidirectional switch, S7 as shown in Fig.1.. A modified space vector PWM for voltage-fed ZSI suitable for variable frequency AC drives has been proposed in [8]. The inductor current and the capacitor voltage are reduced with third harmonic injection in PWM for the same output voltage resulting in reduced L and C ratings of the Z-network.[9] The constant boost control method is adopted for a ZSI topology in [7]. In this situation, we obtain maximum torque per ampere

as well as maximum efficiency[13].Space vector pulse width modulation (SVPWM) is widely used for drive applications because of its various advantages such as the good DC utilization and less harmonics distortion in the output waveform[10]. In order to use SVPWM for ZSI, conventional space vector control strategy has to be changed to distribute the shoot-through states into the zero vectors without compromise to the active space vector [8] to form modified SVPWM. Indirect field oriented control (IFOC) is proposed for controlling the speed of an induction motor fed by a bidirectional Z-source inverter (BZSI) [12].Vector control of PMSM is presented in [13].

### 3. SYSTEM DESCRIPTION

#### 3.1 . Bidirectional Z-Source Inverter

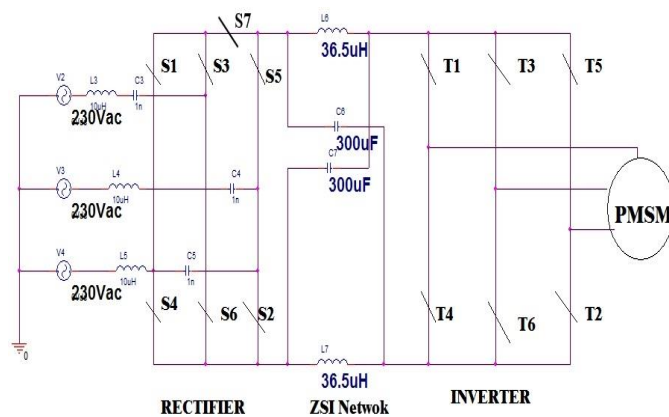

Fig. 1 Topology with ZSI for PMSM drive

Fig.1 shows the configuration of the drive system [14], which consists of a source, rectifier, an impedance network, a conventional voltage-source inverter and a PMSM. The impedance network consists of two identical inductors and two identical capacitors connected in a specific manner to achieve the desired properties. The additional switch S7 can be installed antiparallel to the input diode to eliminate the undesirable operation modes caused by inductor current discontinuous, and enables the system have the ability of bidirectional power flow.

From the equivalent circuits of the ZSI, we have  $L_1=L_2$  and  $V_{C1}=V_{C2}=V_c$ .As described in [1], in the steady state, the operating principle can be expressed as follows:

$$B = \frac{1}{1-2D_o} \quad (1)$$

$$V_{dc} = \frac{V_c}{(1-2D_o)} = B * V_{in} \quad (2)$$

$$V_c = (1 - D_o) * B * V_{in} \quad (3)$$

$$V_{dc} = D_o + (2V_c - V_{in})(1 - D_o) = V_c \quad (4)$$

$$V_o = M * B \frac{V_{in}}{2} \quad (5)$$

Where  $D_o$  is the shoot-through time duty ratio.  $B$  is the boost factor resulting from the shoot-through zero state. $V_{in}$  is the dc source voltage.  $V_{dc}$  is the peak DC-link voltage across the inverter bridge. The average dc-link voltage, equals to the capacitor voltage. In order to use shoot-through vector to control the dc boost of this inverter, PWM methods used are: simple, maximum boost, maximum constant boost control, and modified SVPWM scheme (MSVPWM)[9]. SVPWM technique is possibly the best among all the PWM techniques for variable speed applications because of lower current harmonics and a higher modulation index. So the MSVPWM [4] scheme is adopted in this paper.

#### 3.2. PWM Control Strategy

##### 3.2.1 Modified SVPWM

Space Vector PWM aims at, for a sinusoidal excitation, the voltage space vector will rotate with uniform velocity and the tip of the vector will trace a circle. SVM technique has widely used at industrial applications of power inverter because of lower current harmonics, higher modulation index, fast transient response and simple digital implementation. The objective of SVPWM technique is to approximate the reference voltage vector  $V_{ref}$  using eight space vectors. In SVPWM eight space vectors  $V_0 \sim V_7$  are used, where  $V_1 \sim V_6$  are active vectors,  $V_0$  and  $V_7$  are zero vectors [7]. The basic space vector PWM is shown below. The reference voltage vector is divided in to the two adjacent voltage vectors  $V_1$  and  $V_2$ , if the reference voltage vector is located at sector 1. Switching states of a conventional SVPWM is shown in Fig. 2 and the algorithm for the conventional SVPWM of VSI is briefed as follows[8].The modulation index is

$$M = \frac{u_{ref}}{\frac{2}{\sqrt{3}} * U_d} \quad (6)$$

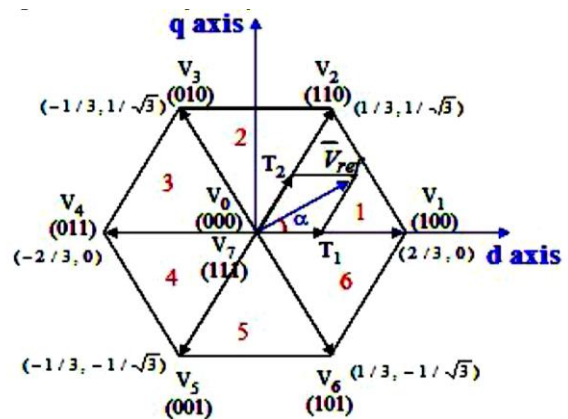

Fig.2.Voltage Vector through a Modified SVPWM of ZSI.

Time for active voltage vector is:

$$T_1 = \frac{T_Z * M * \sin(\frac{\pi}{3} - \gamma)}{\sin(\pi/3)} \quad (7)$$

Time for zero vectors:

$$T_7 = T_8 = \frac{T_o}{2} \quad (8)$$

In conventional VSI, the AC voltage vector is limited. However, with the proper shoot-through control in combination with the SVPWM, i.e., modified SVPWM for ZSI, any AC voltage beyond  $2V_d$ , could be easily implemented. The shoot-through states will be distributed evenly into the switching period. The inserted shoot-through states will not change the equivalent AC voltage vector in SVPWM since the shoot-through states and the zero states in conventional SVPWM appears the same to the AC side by shorting the inverter three-phase output terminals. The shoot-through duty ratio which controls the boosted DC link voltage is [8]:

$$D = \frac{3.T_d}{T_s} \quad (9)$$

### 3.3. Drive System

By applying flux and torque decoupling theory an efficient control scheme called vector control can be developed for PMSM. Upto the rated speed direct axis component of armature current is zero and only quadrature axis component exists. Thus up to rated speed, the control is achieved by ZSI inverter voltage after adjusting the frequency to the value corresponding to required speed by proper PWM technique. For speeds above rated speed the operating point is selected in such a way that the d-axis component of current is minimum. Stator voltage equations are given by [6]

$$\begin{bmatrix} V_{sd} \\ V_{sq} \end{bmatrix} = \begin{bmatrix} R + pL_d & -\omega_e L_q \\ \omega_e L_d & R + pL_d \end{bmatrix} \begin{bmatrix} I_{sd} \\ I_{sq} \end{bmatrix} + \begin{bmatrix} 0 \\ \omega_e \lambda_{pm} \end{bmatrix} \quad (10)$$

where  $V_{sd}$ ,  $V_{sq}$ ,  $I_{sd}$  and  $I_{sq}$  are d- and q-axis voltages and currents respectively,  $R$ ,  $L_d$ , and  $L_q$  are motor armature resistance, d- and q-axis inductances respectively, and  $\omega_e$ ,  $\lambda_{pm}$  are electrical angular frequency and flux linkage respectively.

The electromagnetic torque is obtained as,

$$T_e = 3P \frac{[\lambda_{pm} I_{sq} + (L_d - L_q) I_{sd} I_{sq}]}{2} \quad (11)$$

#### 3.3.1. Operating principle of vector Controlled PMSM drive

Fig.8 shows the block diagram of the vector controlled PMSM drive. The drive consists of speed controller, position signal resolver, current sensors, pulse width modulator (PWM), MOSFET based ZSI and PMSM. The rotor speed ( $\omega_r$ ) is compared with the reference speed ( $\omega_r^*$ ) and the error in speed ( $\omega_e$ ) is processed in the speed PI controller, which generates the reference torque ( $T_k^*$ ). This reference torque is limited using a limiter and the limited reference torque ( $T_r^*$ ) is used to generate the q-axis reference current ( $i_q^*$ ) [13]. Similarly, from the rotor speed of the motor, the d-axis current ( $i_d^*$ ) is decided using the field weakening controller above rated speed. Both these d-axis and q-axis stator currents generate three phase

reference currents ( $i_a^*$ ,  $i_b^*$  and  $i_c^*$ ), which are compared with the sensed winding currents ( $i_a$ ,  $i_b$  and  $i_c$ ) of the PMSM. The current errors are fed to the PWM current controller, which generates the switching signals for the ZSI. These, in turn, control the stator phase currents of PMSM, thereby controlling the speed of the motor. q and d axes currents are constants in rotor reference frames, since torque angle is constant for a given load torque.

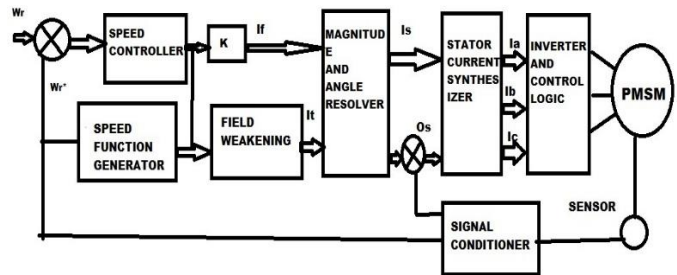

Fig.3.Vector Control of PMSM

In practice, considering the motor maximum line current amplitude and maximum available voltage,

$$I_{sd}^2 + I_{sq}^2 \leq I_{smax}^2 \quad (12)$$

$$V_{sd}^2 + V_{sq}^2 \leq V_{smax}^2 \quad (13)$$

Generally, as the DC-link voltage of inverter keeps constant,  $V_{smax}$  will also keep constant. As  $\omega_e$  is larger than the rated speed of motor, a field weakening strategy should be used to provide the motor a high speed operation.

However, the corresponding current amplitude will increase such that the copper loss will increase. Another strategy is used to provide the motor a high speed operation by boosting the  $V_{dc}$  as  $\omega_e$  is increased. The ZSI provides an adjustable boost DC-link voltage when the PMSM needs to operate in a high-speed region. In the speed PI controller, input parameter is the rotor speed and the output is maximum amplitude of q-axis current it will limit the motor maximum line current amplitude [6].

When the rotor speed  $\omega_r$  is less than the rated speed  $\omega_b$ , the ZSI works without boost and the DC-link voltage command  $V_{dc}^*$  equals to the input battery voltage. The  $V_{dc}^*$  increases linear proportional to speed. The relationship between the DC-link voltage command and the speed is expressed as [6]

$$V_{dc}^* = V_{in} \quad \omega_r \leq \omega_b \quad (14)$$

$$V_{dc}^* = V_{dcmax} \quad \omega_r > \omega_{max} \quad (15)$$

$$V_{dc}^* = \frac{V_{in} \cdot \omega_r}{\omega_b} \quad \omega_b < \omega_r \leq \omega_{max} \quad (16)$$

Above the rated voltage as the motor in the high speed operation.

4. RESULTS AND DISCUSSIONS

Table.1. Simulation Parameters

Parameter	Value
Bidirectional ZSI parameters	
Inductance	36.5 $\mu$ H
Capacitance	300 $\mu$ F
Switching Frequency	10 KHz
PMSM Parameters	
Voltage	300V,50Hz
Rated Torque	6 Nm
Rated Speed	4500 RPM
d-axis inductance (Ld)	2.075 mH
q-axis inductance (Lq)	2.075 mH

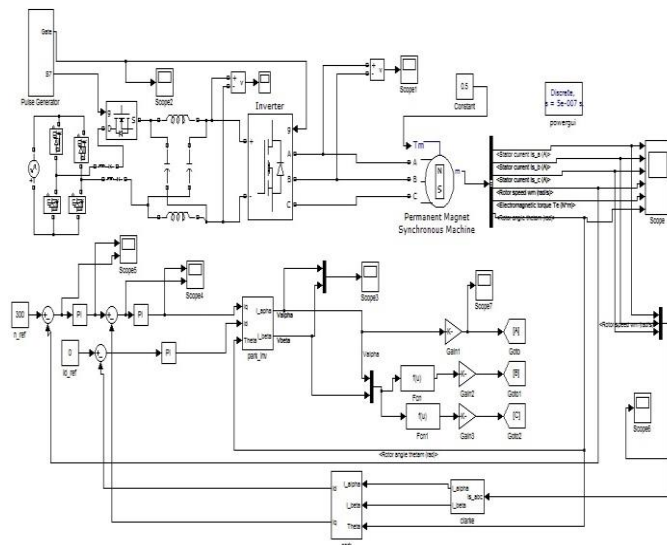

Fig.4.MATLAB/Simulink simulation diagram of ZSI control of PMSM

Simulation is performed in MATLAB/Simulink software by using the above parameters and the following results are obtained. In the rated speed operation, the ZSI works without shoot-through and the DC-link voltage equals to the input voltage.FFT (Fast Fourier Transform) analysis of the obtained waveforms also shown.

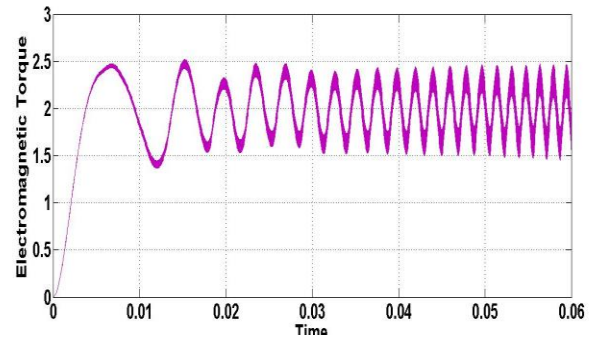

Fig.5 .Electromagnetic Torque at 50% load

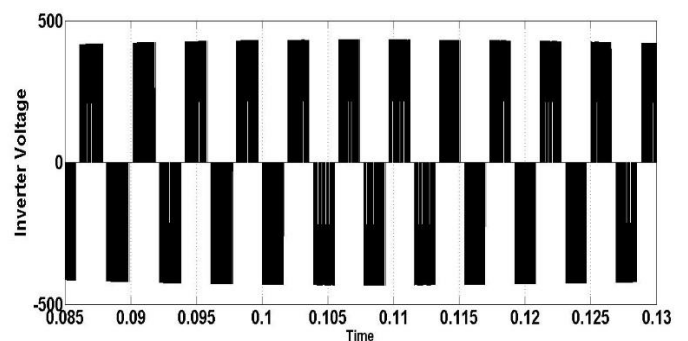

Fig.6 .Inverter Output voltage

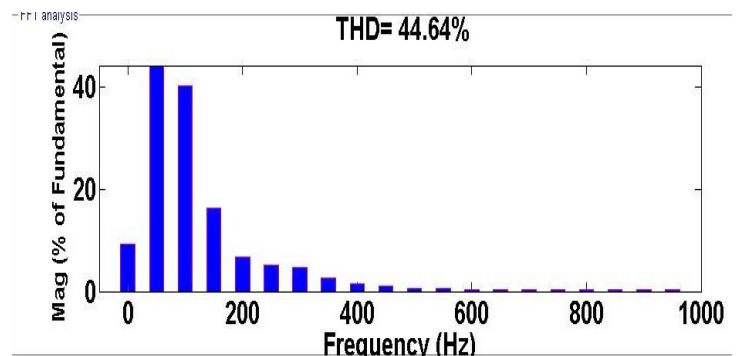

Fig.7 .FFT analysis of Inverter output voltage

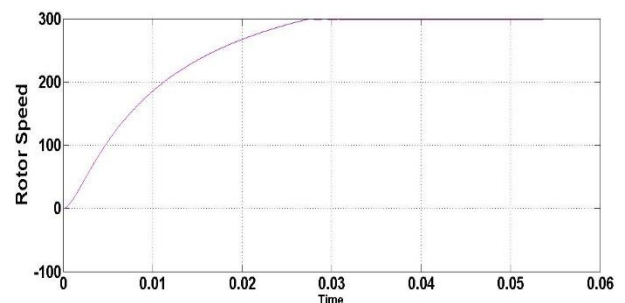

Fig.8 .Rotor Speed

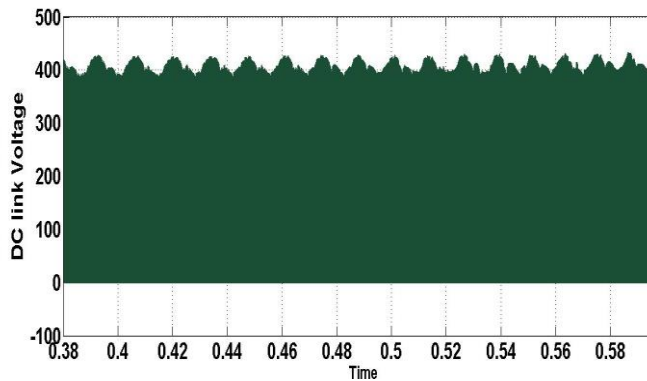

Fig.9 .DC link Voltage

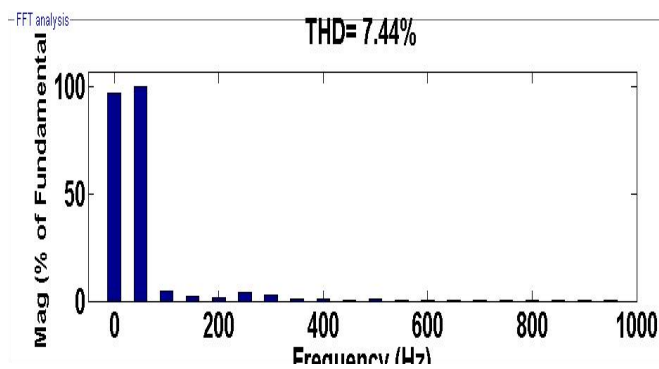

Fig.10 .FFT analysis of Stator Currents

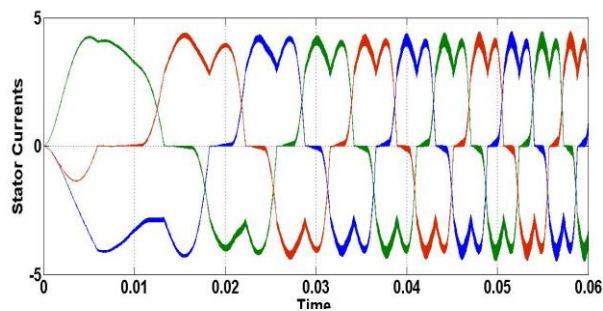

Fig.11 .Stator currents

Harmonic losses caused by PWM carrier frequency can be minimized by increasing inverter switching frequency. When Motor speed increases, high dc link voltage causes motor to draw high current for constant load torque. When desired speed increases stator current increases. It will be small since torque gets reduced at higher speed. For the speeds higher than half the maximum speed, due to lack of voltage, the speed cannot reach to its reference value. The space vector modulator generates the inverter control signals, which ensures fixed inverter switching frequency. So the inverter switching frequency is significantly increased, and the associated torque ripple and current harmonics can be considerably reduced.

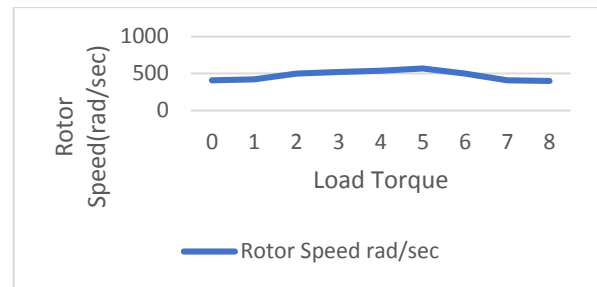

Fig.12.Results of varying Load Torque and Constant DC link Voltage of 600V

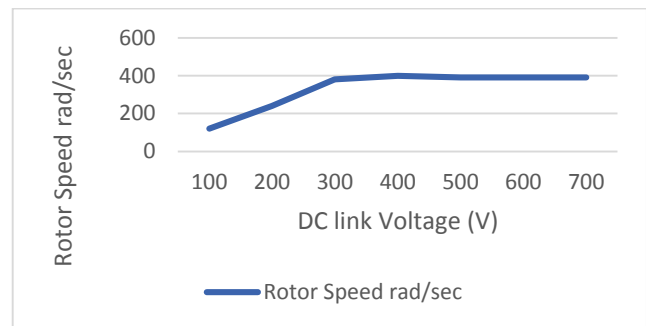

Fig.13.Results of varying DC link Voltage and Constant Load Torque of 2 Nm

### 5. EXPERIMENTAL RESULTS

In order to verify the PMSM drive system, a laboratory prototype of bidirectional ZSI is designed and implemented. For the realization of the proposed control methods a microprocessor board based on a PIC18F4550 has been chosen. Switching frequency of the system is 10 kHz. Investigated the various waveforms through an oscilloscope. Fig. 14 shows the block diagram of the system configuration.

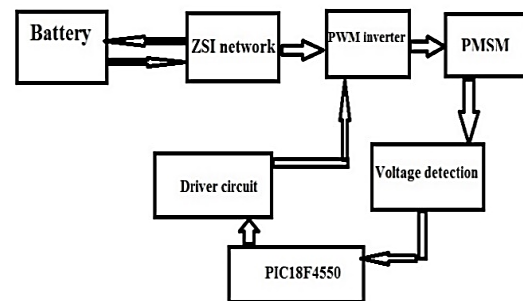

Fig.14..Block diagram of experimental setup





Fig.15..Prototype of PMSM fed by Z-Source Inverter

The experimental set-up is shown in Fig. 15. For switches (S1–S7) of the bidirectional ZSI, MOSFETIRF250 is used. Fig. 16 shows DC-link voltage which are quite consistent with the simulation results.

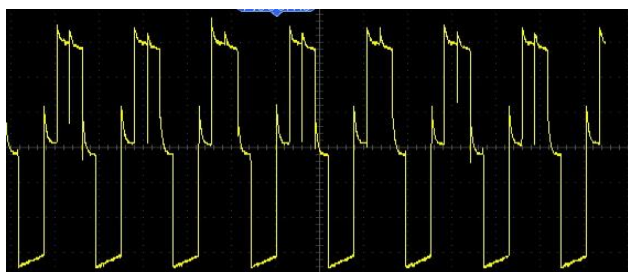

Fig.16. Inverter Output of 24V in Shoot-through mode

Motor Speed Depends on DC link Voltage of Z-Source Inverter. So that by Controlling the DC link Voltage motor can work in Normal mode and shoot-through modes.

$$V_{dc}^* = V_{in} \quad \omega_r \leq \omega_b \quad (17)$$

$$V_{dc}^* = V_{dcmax} \quad \omega_r > \omega_{max} \quad (18)$$

The shoot-through duty ratio can also be adjusted to run the motor on desired speed. The capacitor voltage and stator currents changes correspondingly. And the controller adjusts the speed to required level.

## 6. CONCLUSION

This paper has presented a vector controlled PMSM drive system with bidirectional ZSI. Therefore to extend the speed range of the PMSM and decrease the current amplitude in the high speed operation, the ZSI provides an increasing DC-link voltage by gating on both the upper and lower switches of the same phase leg, as the rotor speed is greater than the rated speed. Hence, the reliability of the system is greatly improved because the shoot through can no longer destroys the circuit. Since, it is a single stage structure, the efficiency of the system

also improved. The simulation and experimental results verify the system.

## REFERENCES

- [1] F. Z. Peng, —Z-source inverter, IEEE Trans. Ind. Appl., vol. 39, no. 2, pp. 504–510, Mar. /Apr. 2003.
- [2] Suresh Maganti, P. Bapaiah, M. Tech., LMISTE. “Advanced Pulsewidth Modulation for Z-Source Inverters Fed PMSM Drive Application” International Journal of Latest Advances in Power System Operation and Energy Management (IJPSEOM) ISSN: 2319-8885 Volume-4, Issue-4, 2014
- [3] F. Z. Peng, X. M. Yuan, X. P. Fang, and Z. M. Qian. ”Z-source inverter for adjustable speed drives”, IEEE Power Electron. Lett., vol. 1, no. 2, pp. 33–35, Jun. 2003. G. O. Young, “Synthetic structure of industrial plastics (Book style with paper title and editor),” in *Plastics*, 2nd ed. vol. 3, J. Peters, Ed. New York: McGraw-Hill, 1964, pp. 15–64.
- [4] Jingbo L., Jiangang h., Longya X.. A modified space vector PWM for z-source inverter-modeling and design. Proc. IEEE Electrical Machines and Systems. Conf., 2005, pp. 1242–1247
- [5] T. Quang-Vinh, et al.. Algorithms for Controlling Both the DC Boost and AC Output Voltage of Z-Source Inverter. IEEE Transactions on Industrial Electronics, vol. 54, pp. 2745–2750, 2007.
- [6] P. Liu H.P. Liu. ” Permanent-magnet synchronous motor drive system for electric vehicles using bidirectional Z-source inverter”. IET Electr. Syst. Transp., 2012, Vol. 2, Iss. 4, pp. 178–185
- [7] K. Supraja, K. Suresh. ”An Optimizing Methodology of ZSI with Suitable PWM Control Techniques” . IJSR, Volume 3 Issue 9, September 2014
- [8] Jingbo Liu, Student Member IEEE, Jiangang Hu and Longya Xu, A Modified Space Vector PWM for Z-Source Inverter - Modeling and Design Department of Electrical and Computer Engineering, The Ohio State University.
- [9] T. Meenakshi I K. Rajambal 2; “Identification of an Effective Control Scheme for Z-source Inverter”; Asian Power Electronics Journal, Vol. 4 No.1 April 2010
- [10] Yu Tang, Member, IEEE, Shaojun Xie, Member, IEEE, and Chaohua Zhang; An Improved Z-Source Inverter; IEEE TRANSACTIONS ON POWER ELECTRONICS, VOL. 26, NO. 12, DECEMBER 2011
- [11] X. Haiping, F. Z. Peng, L. Chen, and X. Wen, “Analysis and design of Bi-directional Z-source inverter for electrical vehicles,” in Proc. APEC, pp. 1252–1257, 2008.
- [12] Omar Ellabban, Joeri Van Mierlo, and Philippe Lataire; ”Control of a Bidirectional Z-Source Inverter for Electric Vehicle Applications in Different Operation Modes”; Journal of Power Electronics, Vol. 11, No. 2, March 2011
- [13] Ravindra Kumar Sharma\*, Vivek Sanadhya\*, Laxmidhar Behera and S Bhattacharya; ”Vector Control Of A Permanent Magnet Synchronous Motor”; 2008 IEEE
- [14] Sengodan Thangaprakasy and Ammasai Krishnan. ”Current Mode Integrated Control Technique for Z-Source Inverter Fed Induction Motor Drives”. Journal of Power Electronics, Vol. 10, No. 3, May 2010